

General Description

The **DENIS Chain Conveyors** are for the transport of bulk materials, such as cereals, granules, ground materials.... with a controlled flow, the conveyors provide a uniform and consistent mass flow and offer the following advantages:

Functional and practical: unit construction, sealed, wide choice of possible configurations: horizontal, inclined, with bend...., alternative types of drive, inlets and outlets pre-positioned as required, minimum residue left, easy to build, compact

Reliable and versatile: different configurations to suit different products and requirements: single direction, transfer, double deck, reversible, discharge...

Robust and economical: with ISO chain, low maintenance

Meticulous preparation and manufacture provide quality: the standard paint finish starts with degreasing, then phosphate primer, before the final coats which are baked at 180°C and applied to each individual part

Options: White food quality paint, hot dipped galvanising

Safety: this equipment conforms with the European Standards for safety and strength and with **ATEX**, the European Explosion prevention requirements

Performance

Type	Sections	Throughput (*)		ISO Chain Speed	Maximum Power
		t/h (**)	m ³ /h		
L 200	200 x 314 mm	30	40	0.43 m/sec	1.5 kW
L 250	250 x 314 mm 250 x 418 mm	50	66	0.45 m/sec	7.5 kW 11 kW
L 310	310 x 418 mm	100	133	0.47 m/sec	22 kW
L 360	360 x 560 mm	150	200	0.54 m/sec	22 kW
L 420	420 x 560 mm	200	266	0.54 m/sec	30 kW
L 500	500 x 610 mm	300	400	0.60 m/sec	45 kW

(*) Throughputs given are for horizontal operation

(**) Density 750 kg/m³

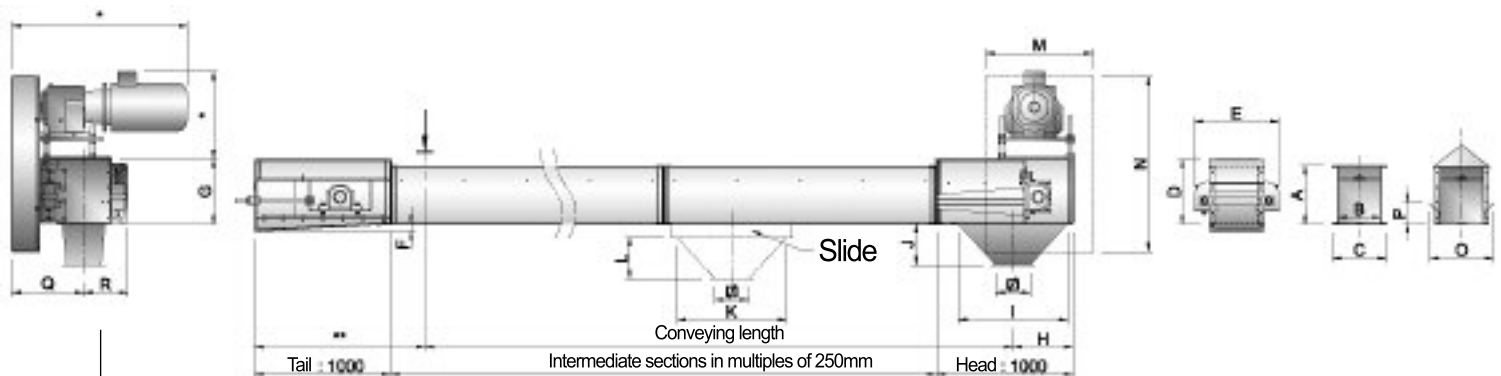

Depends upon size of drive installed

Standard dimensions (mm)

Type	□	A	B	C	D	E	F	G	H	I	J	K	L	M	N	O	P
L 200	160	320	200	286	348	365	26	346	290	500	185	500	185	653	745	358	137
L 250	200	320	250	336	348	428	26	346	440	800	310	500	185	653	745	407	144
L 310	250	424	310	396	474	680	52	476	440	800	300	800	300	786	1280	469	150
L 360	350	564	360	448	620	740	52	612	440	800	287	800	287	786	1350	601	198
L 420	350	564	420	508	620	800	52	612	440	800	350	800	350	786	1350	661	198
L 500	400	620	500	588	620	900	52	612	440	800	350	800	350	786	1350	741	198

A wide range of chain conveyors in standard or purpose built form are available to handle at different throughputs all types of bulk products, such as granules, powders, etc... and therefore suitable for all your installations.

Characteristics

A Head

with large diameter high grade steel shaft – choke indication – bearings either pillow block or flange on certain models

Options:

- Sealed bearings and special bearings
- Recycling assembly
- Reversible and double deck operation
- Outlet slide for recycling assembly

B Drive

from foot mounted geared motor – via chain and sprocket

Options:

- Chain speed to suit product
- Drive type according to requirement
- Shaft mounted gearbox, (in line or right angle types)
- In line geared motor with flexible coupling and guard
- Variable speed drive using inverter

D Tail

with large diameter high grade steel shaft – Smooth profile tail wheel – Chain tensioning system at front or rear

Options:

- Sealed bearings, or special bearings
- Choke detector – Works in both directions

E Chain

conforms to ISO standard – Has rubber cleaning flights

Options:

- Cleaning flights in PEHD (instead of rubber)
- Detachable polyamide cleaning flights
- Recycling buckets
- Oil free chain
- Matrix chain
- Wear strips in PEHD with steel guides or monobloc PEHD
- Extra deep cleaning flights (in steel or PEHD)

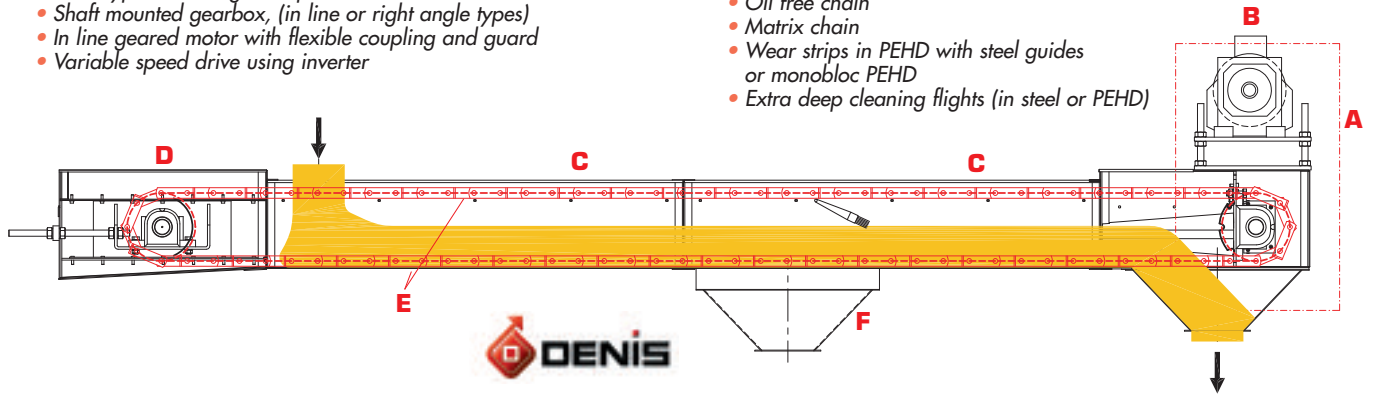

C Intermediate Trunking

standard sections in heavy duty steel – bolted and sealed bottoms – flat top cover – lower wear strip in steel, bolted to bottom, avoids wear of the bottom plate – upper return rail

Options:

- Increased metal thickness of bottom plate, or in stainless steel, PEHD, or creusabro
- PEHD wear strip
- Product flow detector
- Inclined conveyors with anti-lift rail
- Pitched top cover in galvanised steel
- Inspection windows on trunking sides
- Interior white food quality paint

F Intermediate Outlets

with cleaning brush on chain and slides

- Electric
- Electro-pneumatic
- Manual – handwheel
– rack and pinion operated

Steelwork

high quality gloss paint finish

Options:

- Galvanised finish
- White food quality finish

Adaptations

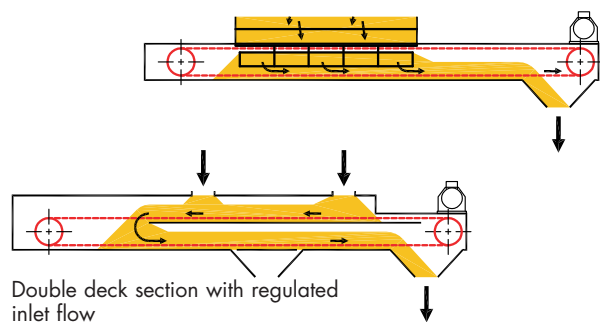

Pit discharge:

- Basic lateral inlets,
 - Lateral inlets for special discharge
- Control of throughput by regulating slide or variable speed

Double deck section with regulated inlet flow

Double deck section with control slide for unregulated entry



This equipment meets with the standards for safety and strength



This equipment conforms to the **ATEX** requirements

Accessories

- Connections, pipework, mobility
- Safety: speed sensor, product flow detector, temperature sensors

Applications

There are different specifications suited to numerous types of activity

Agro-cereal sector

- Agriculture
- Commercial grain
- Animal feeds
- Milling, etc

Industrial sector

- Minerals
- Fertilizer, etc